

# Classic CX Glass

## TWO DRAWER RANGE



Our Classic CX Glass Two Drawer Range is perfect for those that have limited kitchen space but still want a big focus on style. It features a Vitalight Humidity Drawer, a Non-Plumbed Automatic Ice Maker and whisper quiet energy efficient Inverter Technology – making it the quietest fridge in its class.\*



### MR-CGX328ER

600W x 660D x 1698H mm  
Left Hand Available in White Glass Only

328 Litres

### MR-CGX363ER

600W x 660D x 1820H mm  
Left Hand Available in White Glass Only

363 Litres



White Glass



Black Glass

#### Glass Panel Finish

Make a true style statement in your kitchen with the stunning glass flat panel doors that are easy to clean and dent resistant.

#### Humidity Drawer with Vitalight Technology

Slow down the wilting process of leafy greens and maintain their original vitamin and antioxidant levels with the unique Vitalight Amber LED Lighting System. Fruit and vegetables stored in this specially designed Humidity Drawer with its integrated Vitalight Technology will last significantly longer in comparison to conventional vegetable crisper bins.

#### Non-Plumbed Automatic Ice Maker

Always have fresh, clean ice with the Non-Plumbed Automatic Ice Maker. As there is no separate plumbing connection required, this cost-effective approach to ice making means the fridge can be placed anywhere in the kitchen, not just near existing pipe work. Simply fill the removable water tank and the ice maker is ready to go.

#### Freezer Drawer

Store and organise flat pack items like meat packs in the top tray, and slide it back to reveal a large drawer with even more storage space for those bulkier items such as ice cream tubs. The easy to remove drawers also make cleaning a breeze.

#### Supercool Chilling Case

Keep meat and fish fresher for longer without having to freeze them. The Supercool Chilling Case is ideal for storing fresh meat for up to seven days and fish for up to five days without the need of a freezer.



\*300 – 399L Multi Drawer Category

## 1. Refrigerator Compartment

- Tempered Glass Shelves can hold up to 100kg
- Sliding Utility Case perfectly stores deli items or is an additional chilling space for beverages
- Supercool Chilling Case stores meat and fish for up to seven days
- Door Alarm

## 2. Humidity Vegetable Drawer

- Vitalight Technology keeps fruit and vegetables fresher for longer
- Sliding Top Shelf
- Removable internal bin for easy cleaning

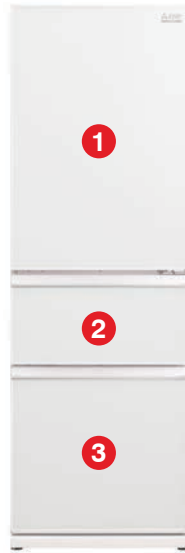

## 3. Freezer Drawer

- Non-Plumbed Automatic Ice Maker
- Sliding Upper Tray perfectly stores flat pack items
- Removable internal bin for easy cleaning
- Drawer Alarm

## CGX 328/363 Specifications and Features

Model	MR-CGX328ER			MR-CGX363ER		
Colour	White Glass / Black Glass			White Glass / Black Glass		
Left Hand Option	White Glass Model Only			White Glass Model Only		
Capacity (Litre)	Gross			Gross		
Refrigerator	180			215		
Freezer Drawer	80			80		
Vegetable Drawer	68			68		
<b>TOTAL</b>	<b>328</b>			<b>363</b>		
Dimensions (mm)	Width	Height	Depth	Width	Height	Depth
	600	1698	660	600	1820	660
Clearance (mm)	Sides	Top	Back	Sides	Top	Back
	20	100	50	20	100	50
Weight (kg)	72 Gross / 65 Net			76 Gross / 68 Net		
Energy Efficiency	Compressor	Neuro Inverter		Compressor	Neuro Inverter	
	Refrigerant	R600a		Refrigerant	R600a	
	Power Consumption	304kWh/Y		Power Consumption	320kWh/Y	
Energy Rating	3.5 Stars			3.5 Stars		
Sound Rating	17dBA – Quietest in its class*			17dBA – Quietest in its class*		

\*300 – 399L Multi Drawer Category



### New Zealand Warranty

- General 24 Months Parts & Labour Warranty
- Neuro Inverter Compressor 10 Year Parts Only Warranty

## Basic Installation Dimension Requirement\*\*

### Classic Glass CGX328ER

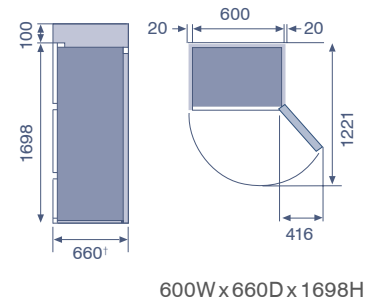

600W x 660D x 1698H

### Classic Glass CGX363ER

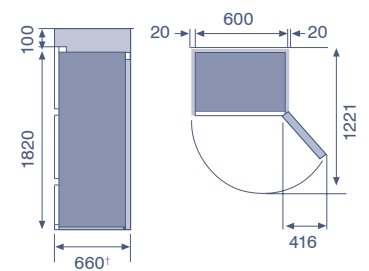

600W x 660D x 1820H

\*667mm with kickplate included.

\*\*Variances in product dimensions may occur. It is important that basic installation dimension requirements are followed.



Black Diamond  
Technologies Limited



Exclusive New Zealand  
Partner Since 1981



For more information please visit our website or call our Customer Service Team.

[www.mitsubishi-electric.co.nz](http://www.mitsubishi-electric.co.nz) | 0800 784 382

PRINTED DECEMBER 2021